

## Integración

## Congelador Vertical

## Tecnología DEFROST

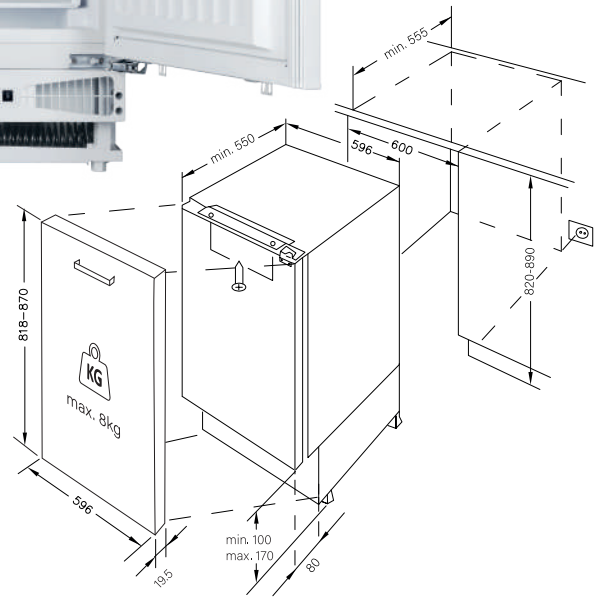

### POTENCIAS

Consumo energético anual (kWh/año)	176
Consumo energético diario (kW/24h)	0,422

### ESPECIFICACIONES

Instalación	Integración
Categoría del producto	Congelador vertical
Calificación energética reescalada	E
Capacidad total (L)	95
Clase climática	ST
Congelador	4*
Ruido (dB)	40
Puerta reversible	Si
Regulación en altura	Si
Peso Neto/Bruto (Kg)	32,5/35

### MEDIDAS Alto x Ancho x Profundo

Producto (cm)	82 x 59,6 x 55
Embalaje (cm)	86 x 62,5 x 57

### CARACTERÍSTICAS

- Acabado BLANCO
- Display LED
- Compresor Silent design
- Tecnología DEFROST
- Función Fast Freezing
- Control de temperatura electrónico
- Equipamiento interior con perfiles cromados
- 3 cajones Freezer Box