

CMPTRAL-SG60



400m³/h de extracción

Campana pirametal

Cristal templado

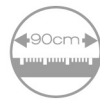
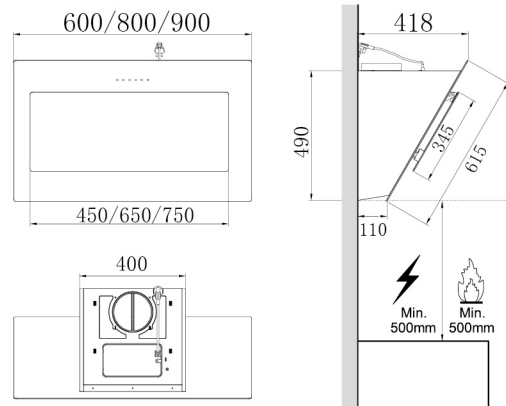
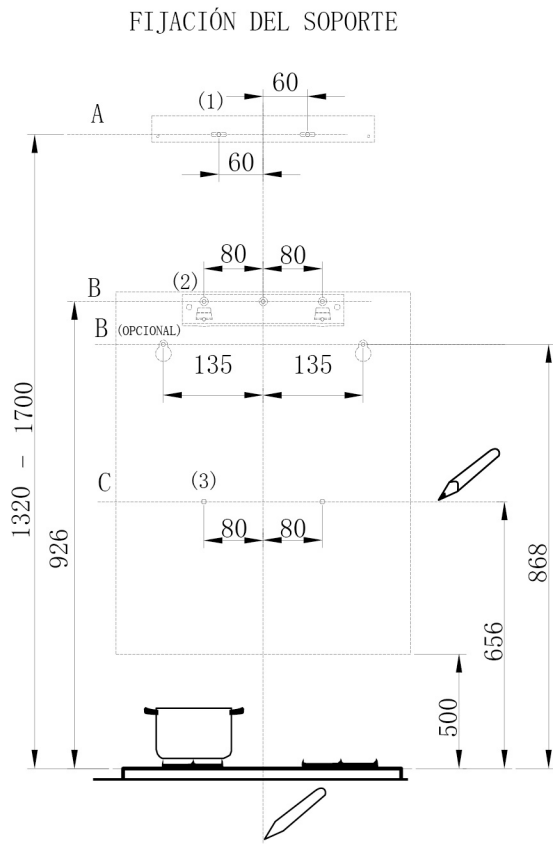

EAN: 8436546193692

DATOS TÉCNICOS

Ancho	60 cm
Potencia de extracción	400m ³ /h
Potencia de motor	210 W
Potencia de luz	1 x 1.5 W
Diámetro interior tubo de aire	15 cm
Ruido	48 - 67 dB
Consumo anual	49 kWh/año

MEDIDAS

59,7 x 41,5 x 39,4 cm

CARACTERÍSTICAS

- Clasificación energética A
- Campana tipo T invertida pirametal
- Cristal templado NEGRO
- 3 velocidades
- Filtro de aluminio fácil de limpiar
- 2 luces LED