

CMPTRAL-BT90



800m³/h de extracción

Campana pirametal

Cristal templado

FIJACIÓN DEL SOPORTE

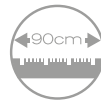
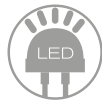
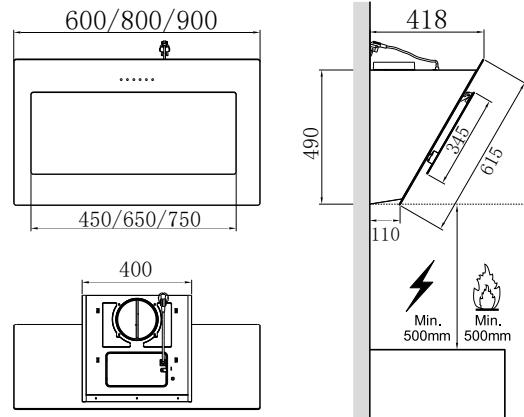
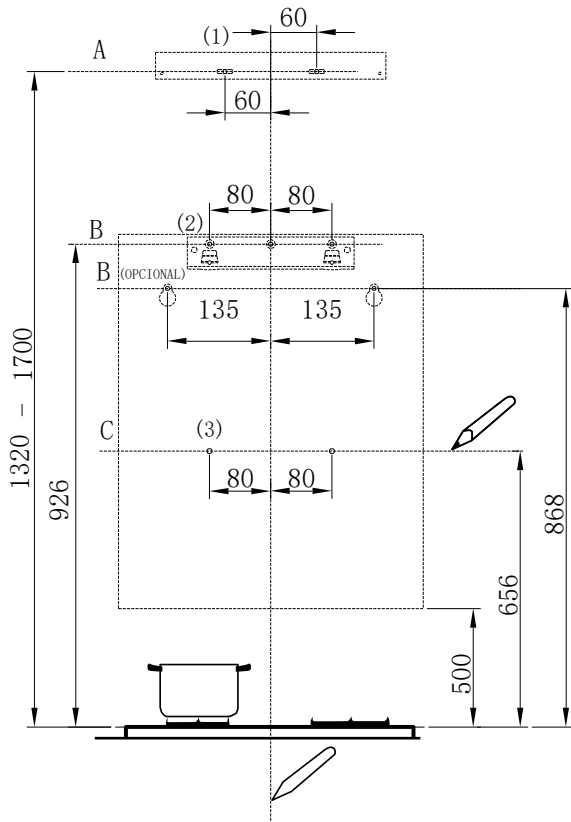

EAN: 8436546188735

DATOS TÉCNICOS

Ancho	90 cm
Potencia de extracción	800m ³ /h
Potencia de motor	210 W
Potencia de luz	2 x 1.5 W
Diámetro interior tubo de aire	15 cm
Ruido	48 - 67 dB
Consumo anual	49 kWh/año

MEDIDAS

50 x 90 x 42 cm

CARACTERÍSTICAS

- Clasificación energética A
- Campana tipo T invertida pirametal
- Touch Panel (panel táctil)
- Cristal templado NEGRO
- 3 velocidades + potencia intensiva
- Filtro de aluminio fácil de limpiar
- 2 luces LED