

CMPT-ISH99X



800 m³/h de extracción

Campana de isla

Ancho 60 cm

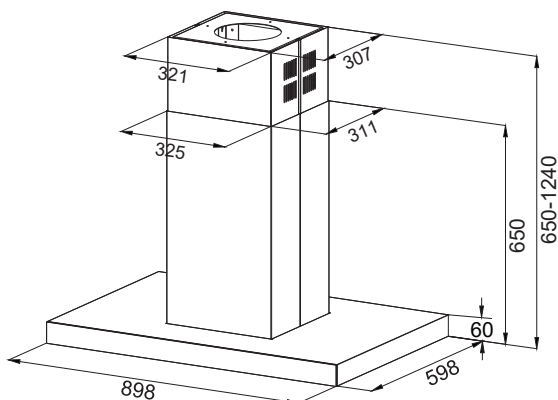
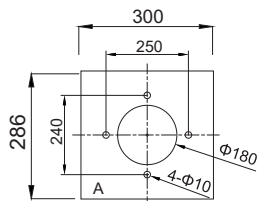
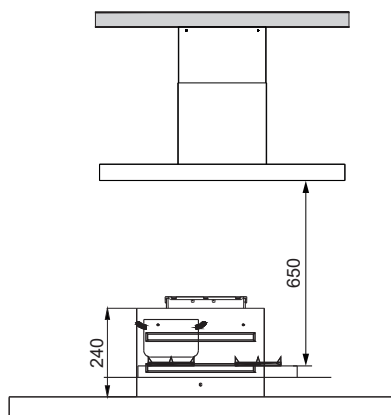

EAN: 8436546195061

DATOS TÉCNICOS

Ancho	60 cm
Potencia de extracción	800m ³ /h
Potencia de motor	250 W
Diámetro interior tubo de aire	120 mm
Ruido	67 dB
Peso	24 Kg
Potencia de luz	2 x 1,5 W
Consumo energético	56,35 kWh

MEDIDAS

90 x 60 x 65 cm

CARACTERÍSTICAS

Clasificación energética A
Acabado en INOX
Campana de isla tipo T invertida
3 velocidades
Sistema de control electrónico
3 Filtros de aluminio lavables
Filtro con 5 capas
Filtro de carbono incluido
2 luces LED