

CMPE-63X



400m³/h de extracción

Campana de extracción

Ancho 60 cm

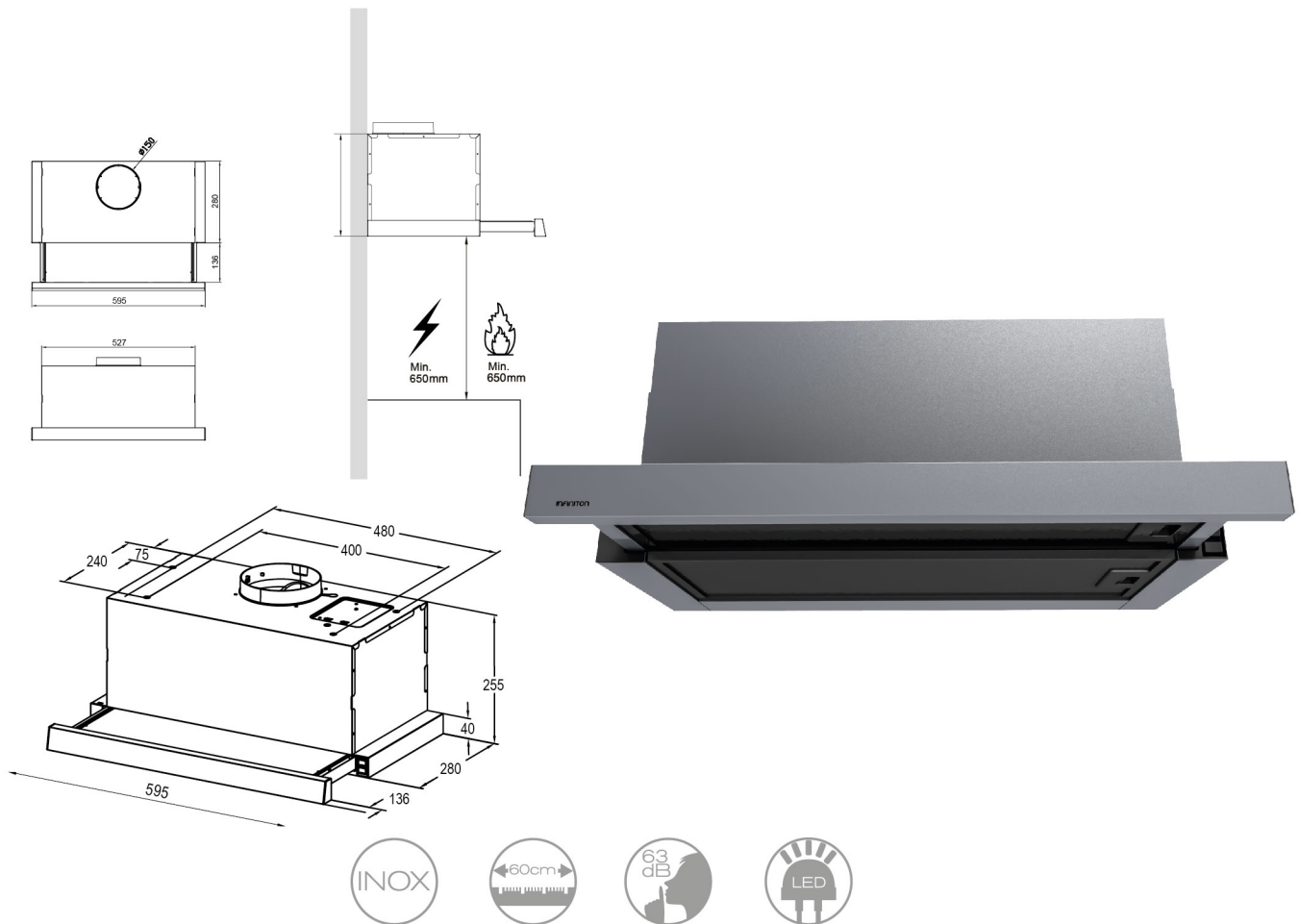

EAN: 8436546192633

DATOS TÉCNICOS

Ancho	60 cm
Potencia de extracción	400m ³ /h
Potencia de motor	205 W
Potencia de luz	1 x 1.5 W
Diámetro interior tubo de aire	15 cm
Voltaje	220-240 V ~/ 50Hz
Ruido	68 dB
Consumo energía anual	53 kWh/año

MEDIDAS

22,5 x 59,5 x 30,8 cm

CARACTERÍSTICAS

- Certificación energética C
- Campana telescópica
- Control mecánico
- 2 Velocidades
- Filtros de aluminio
- Luz LED