

# CMPE-61B



400m<sup>3</sup>/h de extracción

Campana de extracción

Ancho 60 cm

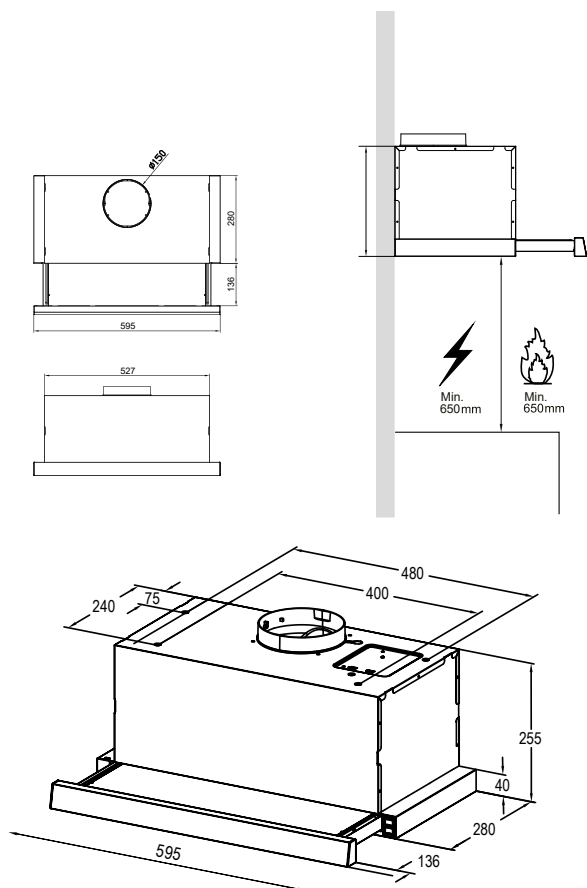

EAN: 8436546192626

## DATOS TÉCNICOS

Ancho	60 cm
Potencia de extracción	400m <sup>3</sup> /h
Potencia de motor	205 W
Potencia de luz	1 x 1.5 W
Diámetro interior tubo de aire	15 cm
Voltaje	220-240 V ~ / 50Hz
Ruido	63 dB

## MEDIDAS

22,5 x 60 x 30,8 cm

## CARACTERÍSTICAS

- Clasificación energética C
- Campana telescópica
- Control mecánico
- 2 Velocidades
- Filtros de aluminio
- Luz LED